

NORSEMEN FOOTBALL

Mesabi Range
Community & Technical
College

Summer Strength &
Conditioning Program



SUMMER STRENGTH & CONDITIONING

May 5, 2009

Dear Norsemen,

This manual contains your conditioning activities for this summer and will give you the opportunity to repeat as champions in 2009. Strength training, flexibility, speed improvement, cardiovascular conditioning, and nutrition are all covered in this manual. You must be at your best in these areas **BEFORE** reporting to fall camp if you are going to obtain optimal performance on the field and make use of your physical skills. Improved strength and conditioning will make us a better football team. You must take it upon yourself to continue your commitment level throughout the summer months.

This program will give you the opportunity to report to camp in top condition but, this will only happen if you are consistent with your workouts and are truly committed to being the best football player you can be. You must complete the workouts prescribed for each day of the summer and put a winning effort into each and every one. Do not let all of your hard work this off season go to waste by taking unscheduled days off during the summer.

During the winter and spring, we have made significant gains by using this program and being consistent with our workouts. Our team gains have been accomplished in a fifteen-week period. There are 42 workout days until you check into camp and you need to make the most out of each one.

You must start now and make your workouts a mandatory part of your daily routine. While the length of time required is not great, the time put in must be quality time. To have quality time you must put all of your mental and physical energy into your workouts. When you do this, you will be putting in quality time and you will have success.

If you need to substitute lifts because of equipment limitations or you are having a problem with any phase of your conditioning, please do not hesitate to contact us. Instructions are included for each workout. Read and follow these instructions carefully.

I hope everyone has a safe and enjoyable summer. I present a challenge to every one of you to report to camp in the best physical condition ever to meet the challenges of another championship season in 2009.

Have a productive and safe summer!

“GO, GO MESABI”

Dan Lind
Head Football Coach
Mesabi Range College
218-748-2422 Office
218-780-1658 Cell
d.lind@mr.mnscu.edu



MESABI RANGE COLLEGE NORSEMEN FOOTBALL 2009



<u>DATE</u>	<u>OPPONENT</u>	<u>SITE</u>	<u>TIME</u>	<u>RESULTS</u>
August				
29 (Sat)	MINNESOTA STATE	St. Cloud	1:00	
September				
5 (Sat)	Ridgewater	Willmar	1:30	
12 (Sat)	CENTRAL LAKES	VIRGINIA	1:30	
19 (Sat)	Minnesota West	Worthington	12:00	
26 (Sat)	Vermilion	Ely	1:30	
October				
3 (Sat)	ROCHESTER	VIRGINIA	2:00	
8 (Thu)	Itasca	Grand Rapids	7:00	
15 (Thu)	FOND DU LAC	VIRGINIA	7:00	
22 (Thu)	NORTHLAND	VIRGINIA	6:00	
<u>State Semi-Finals</u>				
31 (Sat)	TBD	TBD	1:00	
November				
<u>State Championship</u>				
8 (Sun)	TBD	St. Cloud State	1:00	



NORSEMEN FOOTBALL STRENGTH TRAINING

Our strength-training program uses a multiple set periodized approach. As you progress through each phase, the volume (reps) will decrease and the weight will increase. Every lift has a percentage of one repetition maximum (1RM) prescribed for each day of lifting. Follow the prescribed sets/reps, percentages and lifting days. There are charts to help you determine your 1RM and percentages of 1RM. Remember that you must continually push yourself to get stronger. You need to approach every rep of each lift with 100% intensity.

We utilize variations of Olympic lifts (Power Clean, Hang Clean, Dead Lift, and Push Press) and traditional strength training exercises to accomplish our goals. Olympic lifts develop explosive power, which is important in almost every competitive sport. The bar (weight) must move rapidly with these lifts. Proper technique is vitally important when performing Olympic lifts. If you have never had proper instruction on Olympic lifting, we recommend that you not attempt these lifts. Instead, concentrate on the other strength exercises.

When performing non-Olympic lifts, the speed that the bar (weight) is moved should be as follows:

Anytime the weight is lifted, use a count of two seconds

Anytime the weight is lowered, use a count of four second

Rest and recovery is important when doing strength/power training. If do not rest long enough between sets, you train you muscles for endurance. Endurance and power are inversely proportional. Follow the prescribed recovery time between sets. Olympic lifts and heavy loads should have 2½ to 3 minutes of recovery. The other lifts should have a 1-2 minute recovery.

Breathing rhythm is important during lifting. A general rule of thumb is to inhale and expand the chest. Hold your breath during the initial movement of the lift. As you near the completion of the lift, exhale. As you return the weight to the starting position, inhale again.

Training Log sheets are located in the weekly workout section. You will need to write in your 1 rep max in the space provided on the log and use the percent chart provided to see how much to lift for each set. The lifts in our program are divided into two categories, 1) Core Lifts (always in **BOLD** and at the top of the workout log) and 2) Auxiliary lifts (always at the bottom of the workout log).

The core exercises will all be set off a 1-rep max that you will find or off a formula that will find it for you. Your 1-rep max for your core lifts may change during the course of the workout. On the final set of each core exercise, you will lift until failure. If you reach the prescribed number, your 1-rep max should remain the same. If you are unable to complete all the repetitions for the set, you will adjust your 1-rep max down 5 pounds for every 2 missed reps for upper body lifts and 10 pounds for every 2 missed reps for lower body lifts. If you are able to complete more than the prescribed number of repetitions for the last set you will adjust your 1-rep max up 5 pounds for every 2 reps past the set number and 10 pounds for every 2 reps past the set number.

The auxiliary lifts will not have a 1-rep max attached to them or a percent to work out with. The only rule is that you should not work out with same weight for the same reps 2 weeks in a row.

A section in the manual has descriptions, pictures, and video of strength exercises and stretching exercises commonly used. Not every lift is included in the exercise descriptions.

NORSEMEN FOOTBALL STRETCHING EXERCISES

Stretching is easy to learn. But there is a right and a wrong way to stretch. The right way is a relaxed, sustained stretch with your attention focused on the muscle being stretched. The wrong way is to bounce up and down, or to stretch to the point of extreme pain. You should feel a moderate discomfort in the muscle you are stretching. Below are some stretching exercises which will increase your flexibility if done properly. Remember to stretch before and after each workout.

Seated Hamstring

- Sitting with legs full extended and inside of feet touching.
- Keep your ankles flexed (toes pointed up).
- Tuck your chin into chest.
- Extend hands and reach for your ankles.
- Keep your legs as straight as possible.
- Hold Stretch for 15 seconds.

Feet Apart

- Sitting with legs fully extended, spread feet as far as possible.
- Keep your ankles flexed.
- Tuck your chin into chest.
- Extend hands directly in front, reach as far as possible.
- Hold Stretch for 15 seconds.

Feet Apart (right/left foot)

- Sitting with legs fully extended, spread feet as far as possible.
- Keep your ankles flexed.
- Tuck your chin into chest.
- Extend both hands to the right foot.
- Hold stretch for 15 seconds.
- Repeat stretch to the left foot.

Butterfly

- Seated, pull heels together close to the groin.
- Apply pressure with elbows downward.
- Hold stretch for 15 seconds.

Knee Pull

- Lying on back.
- Pull knee to chest and then across your body.
- Hold stretch for 15 seconds.
- Repeat with other leg.

Back Twist

- Sit with right leg straight and left leg crossed over it.
- Rotate body to left and use right elbow on outside of left knee.
- Hold stretch for 15 seconds.
- Repeat stretch for the other side.

Leg Over

- Lay on back with right leg straight.
- Pull your bent left leg over your straight right leg.
- Keep your shoulders flat on the ground.
- Repeat stretch for the other side.

Lower Back

- Lay in a push-up position.
- Gently push your upper body off the ground.
- Keep your hips on the ground.
- Hold stretch for 15 seconds.

Iron Cross

- Lie on your back with arms straight out to your sides.
- Keeping your knee straight, bring your right foot up and try to touch your left hand.
- Return to the starting position and then bring left foot to your right hand.
- Repeat this exercise ten times with each leg.

Scorpion

- Lie on your stomach with your arms straight out to the side.
- Bring your right foot up and try to touch it to your left hand (you will rotate your trunk and bend your knee).
- Return to the starting position and then bring your left foot to your right hand.
- Repeat this exercise ten times with each leg.

Sumo Squat

- Squat with your feet flat on the floor about 12 inches apart and your toes turned slightly outward.
- Place your elbows inside of your thighs, exhale, and push your legs outward with your elbows.

Quadriceps

- Stand holding onto something for balance.
- Flex one knee and raise your heel to your buttocks.
- Slightly flex your supporting leg, exhale and grasp your raised foot with one hand.
- Inhale and slightly pull your heel toward your buttocks without over compressing the knee.
- Hold stretch for 15 seconds.
- Repeat with other leg.

Shoulders

- Grab your right elbow with your left hand.
- Pull your right arm across your chest.
- Keep your right arm parallel to the ground.
- Hold Stretch for 15 seconds.
- Repeat with left arm.

Triceps

- Bending your right arm at the elbow, extend your arms over your head.
- Grab your right elbow with your left hand, behind your head.
- Pull your right elbow with your left hand (pull to the left).
- Hold stretch for 15 seconds.
- Repeat with left arm.

Neck Roll

- Move your head and neck in clockwise circle.
- Move your head in a counter clockwise circle.

NORSEMEN FOOTBALL DYNAMIC WARM-UP

We utilize a dynamic warm-up to get the body prepared for a workout. A dynamic warm-up will increase: heart rate, blood flow, core temperature, muscle elasticity (dynamic flexibility), neuromuscular coordination, joint proprioception & mobility, and enhance your running form. Complete each drill in the order they are listed and before stretching. Remember to always maintain proper arm swing and forward lean.

- 1. HIGH KNEES:** Lean forward slightly at the waist and keep back straight. Sprint the course, taking quick, short, one foot steps for 20 yards. Drive your knees high so that your thigh is parallel to the ground. When you lift one leg, be sure the other leg is fully extended.
- 2. BUTT KICKS:** Lean forward at the waist and keep your back straight. Run on your toes and alternately swing the heel of each foot up to your buttocks for 20 yards. Keep action quick and smooth; produce the swinging at the knee, not the hip.
- 3. PRANCERS:** Lean forward slightly at the waist and keep your back straight. Run on your toes with high knees and alternately swing the heel of each foot up to your buttocks for 20 yards. Keep action quick and smooth; produce the swinging at the knee, not the hip.
- 4. TOE TOUCHES:** Keeping knees locked reach down with your hand to the opposite toe. Bend at the waist and continue on for 20 yards.
- 5. SKIPPING ARM CIRCLES:** Skip a distance of 20 yards while swinging your arms forward in large arm circles. Then skip back to your starting point while swinging your arms backward in large arm circles.
- 6. SHUFFLE ARM CIRCLES:** Start with your arms hanging criss-crossed in front of your body. As you side shuffle, simultaneously swing your arms sideways out away from your body and up over your head and then back down to the starting position. Side shuffle/arm swing 20 yards. Face the same direction and shuffle with arm swings to your starting point.
- 7. PARALLEL SLIDE:** Get into a good hitting stance with knees flexed and shoulders facing squarely forward. Move laterally to your left or right in an over exaggerated basketball slide for 20 yards. Do not allow your feet to touch. The lead foot should be the one in the direction you are headed. Maintain a good center of gravity and low pad level. Keep your eyes forward through the finish line.
- 8. FORWARD LUNGE:** In a walking motion, alternate overextending your stride to the point where your back leg grazes the ground and your front thigh becomes parallel to the ground. Concentrate on using good arm motion. Go for 20 yards.
- 9. REVERSE LUNGE:** In a backwards walking motion, alternate overextending your stride to the point where your back leg grazes the ground and your front thigh becomes parallel to the ground. Concentrate on using good arm motion. Go for 20 yards.
- 10. SIDE LUNGE:** Facing side ways step out and bend the knee keeping the back knee locked. Go down to your thigh is parallel with the ground. Go for 20 yards.
- 11. HIGH KNEE CARIOCA:** Do a carioca (grapevine step) for 20 yards. As you bring your trail leg across the front of your body, bring your knee up as high as you can. Face the same direction and do the high knee carioca back to the starting point utilizing the other leg as the high knee leg.
- 12. QUICK CARIOCA:** Do a carioca (grapevine step) for 20 yards as quickly as you can. Face the same direction and do the carioca back to the starting point utilizing the other leg as the lead leg.

13. LOSE HIP WALK: In a walking motion lift knee up and rotate outward while skipping on the other foot, once the circling foot comes down to the ground the opposite foot should begin to rotate up. Go for 20 yards.

14. LIZARD: Keeping your body 6 inches off the ground move you right arm and leg in one motion forward and then the left. Go for 20 yards.

15. LEG SWING: Stand facing the wall with arms outstretched and hands leaning on the wall. Swing one leg out to the side and then back across the front of your body as far as you can. Repeat this exercise 10 times on each leg. Then stand beside the wall with one hand leaning on the wall. Swing one leg forward and backward as far as you can. Do this exercise 10 times on each leg.

NORSEMEN FOOTBALL SPEED DRILLS

1. FORM STARTS

From a 3 or 4-point track stance fire off the line staying low by keeping hips low, not bending at the waist. Sprint for 20 yards.

2. POSITION STARTS

Using the position specific stance that your position requires sprint for 20 yards.

3. ARM SWINGS

From a standing position use good sprinting arm action. Keep hands relaxed and shoulders loose. Movement in shoulders to bring hands from rib cage to side of face.

4. KNEE DRIVE

Using a wall to lean against drive leg knee up past waist as quickly as possible. Do not rest on the bottom as soon as the ball of your foot touches the ground, explode, and drive your knee up. Do one leg at a time.

5. 30 YARD BUILDUPS

Set up a 60-yard course with 30 yards as the point marked. Start from a standing start into a slow run, concentrating on good running form. Gradually build up speed until you are at full speed at 30 yards, gradually slow down at finish line.

6. 40 YARD BUILD UPS

Set up a 60-yard course with 40 yards as the point marked. Start from a standing start into a slow run, concentrating on good running form. Gradually build up speed until you are at full speed at 40 yards, gradually slow down at finish line.

7. FLYING 10'S

Set up a 40-yard course with the 30 yard point marked. Start running at half speed, building speed at each stride for 30 yards. By the time you reach the 30-yard mark, you should be running at full speed (flying). Continue at this full speed sprinting for the last 10 yards.

9. TALL AND FALL

From a standing position lift your dominate foot off the ground and fall forward. At the last moment, catch yourself with the foot that was off the ground in a good knee bent position. Continue in a 20-yard sprint.

10. START AND STOP

Mark out a 50-yard course. From a standing position, begin to sprint to the first marker. When you get to the first marker drop your hips, settle for a one count, and then sprint to the next cone. Continue through the entire course.

11. ACCELERATION COURSE

Set a 30-yard course in slalom (zig-zag) with varying angles. Set markers every 5-10 yards in the course. Start running slowly and increase speed after each cone. You should be at full speed when you reach the last cone. Sprint 10 yards at your top speed past the final cone.

12. HALF-FULL-HALF

Mark out a 100 yard course with every 20 yards marked. Start running at half speed for the first 20 yards. At the 20-yard point accelerate and sprint full speed for 20 yards. Slow back to the original half speed run for 20 yards. Keep repeating this pattern for the remainder of the course.

13. PRONE AND GO

Start lying on your stomach with arms out to your side. Explode and bring your arms and legs underneath you and sprint for 20 yards.

14. SUPINE AND GO

Start lying on your back with your arms out to your side. Roll to one side, get your arms and feet underneath you, and sprint for 20 yards. Make sure that you roll to both sides.

NORSEMEN FOOTBALL AGILITY DEVELOPMENT

1. PRO AGILITY

- From a three-point stance straddle line 1 facing timer.
- Start by running to the right to line 2.
- Touch line 2 with right hand.
- Sprint back across line 1 to line 3 to the left.
- Touch line 3 with left hand.
- Turn and sprint through line 1.

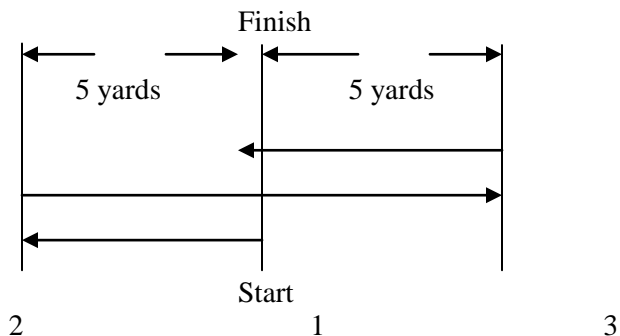

2. 30 YARD SHUFFLE LADDER

- Begin in a two point stance, standing perpendicular to the start line.
- Shuffle to the first line, touch the line with your right foot, and shuffle to the starting line and touch with left foot.
- Shuffle to the second line, touch the line with your right foot, and shuffle through the starting line.

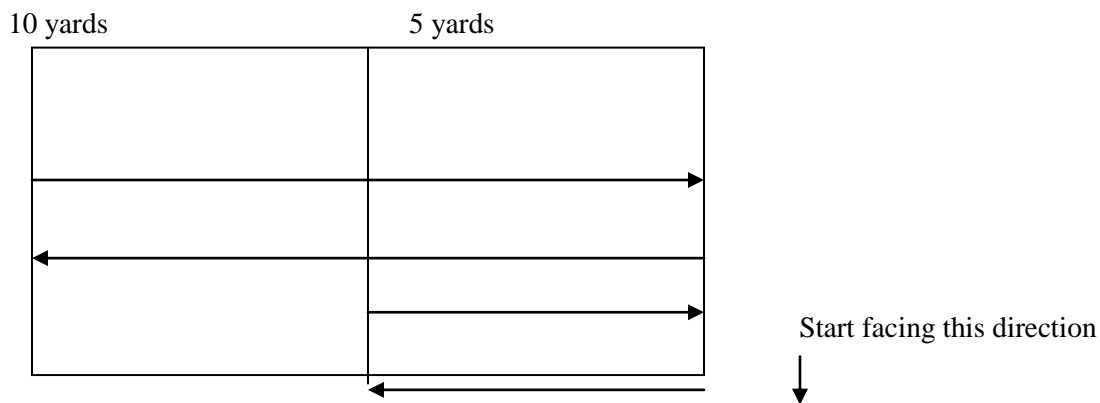

3. 40 YARD LADDER

- Begin in a three point stance on the starting line.
- Sprint to the first line (5 yards), touch the line with your right foot, and sprint back to the starting line and touch it with your left foot.
- Sprint to the second line (10yards), touch the line with your right foot, and sprint back to the starting line and touch it with your left foot.
- Sprint to the first line (5 yards), touch the line with your right foot, and sprint through the starting line.

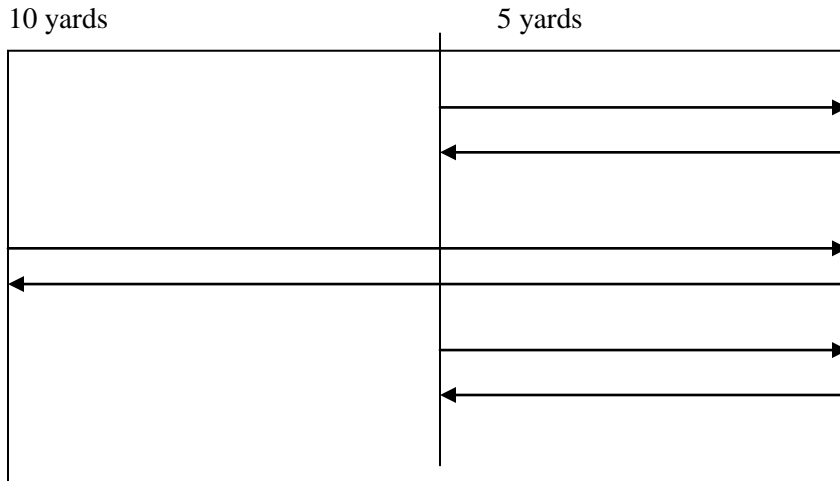

4. 4 CORNER

- Set up four cones as shown below.
- Start at cone A and Shuffle to cone D.
- Sprint to cone C
- Carioca to cone A.
- 1 time around = 1 rep
- Be creative. Reverse directions and sequences.
- Cones should be spaced 10 yards apart.

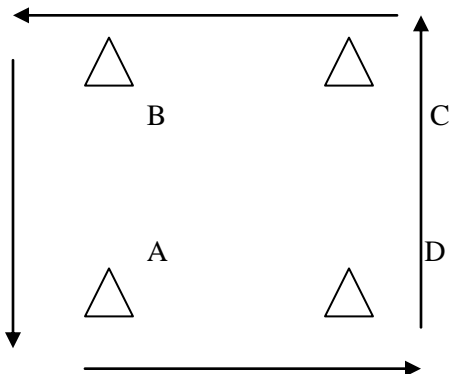

5. ZIG ZAG RUN

- Start in a three point stance, sprint to the first cone, plant the outside foot, use a side step, and cut around the cone.
- Continue to sprint to each cone, planting outside foot and using a side step to cut hard.
- Accelerate from cone to cone this drill should be at full speed.

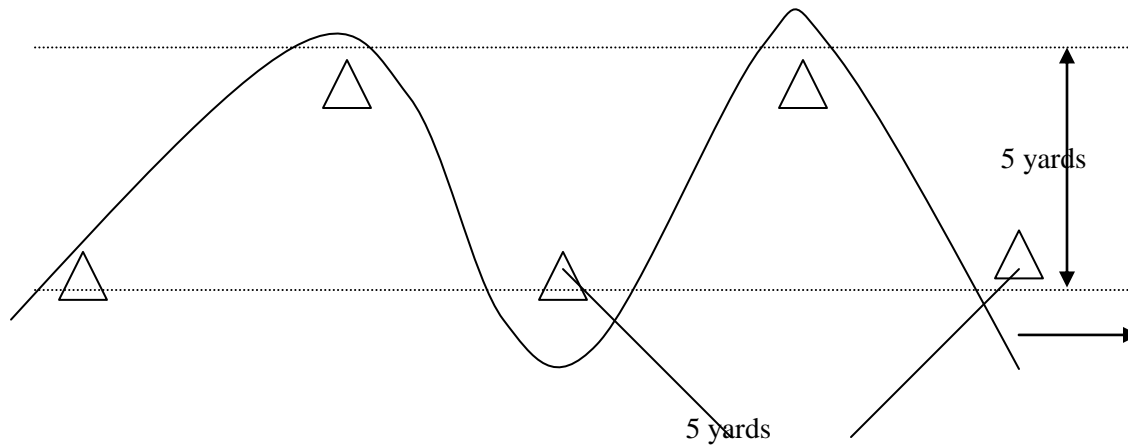

6. CROSS DRILL

- Set up five cones as shown below with 5 yards between cones.
- Start at the middle cone, sprint to the cone to your right and then return to the middle cone and continue through the course to your right touching each outside cone with your right hand and the inside cone with your left.
- Make sure that you also do a set going to your left and touch the outside cones with your left hand and the inside cone with your right hand.

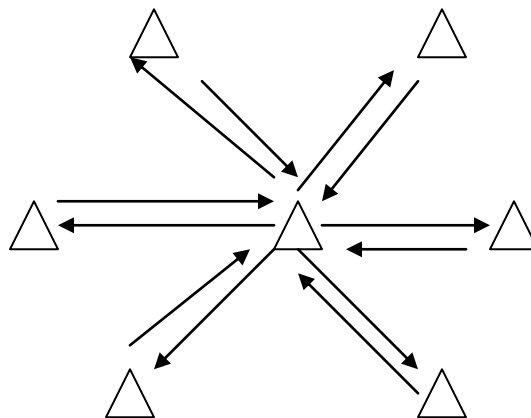

7. T-DRILL

- Position 4 cones so they form a “T”.
- Each cone should be 5 yards apart.
- Start in a 2-point stance at cone 1.
- Backpedal past cone 2.
- Shuffle to cone 3.
- Shuffle, across, past cone 2, continue to cone 4
- Shuffle back to cone 2 and sprint past cone 1.

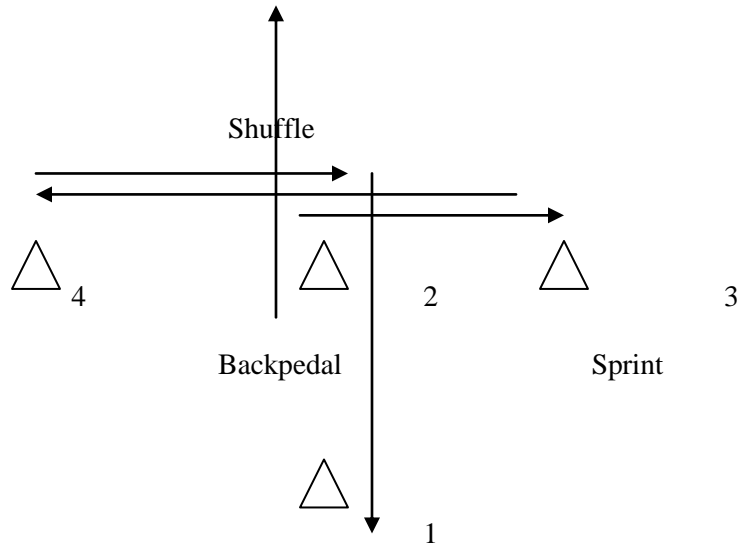

8. LINE DRILLS

- Stand on two feet facing a line on floor. Jump forwards and then backwards over the line as fast as you can for 20 seconds.
- Stand on two feet with your right foot next to a line on the floor. Jump from side to side over the line as quickly as you can for 20 seconds.
- Stand on one foot facing a line on the floor. Jump forwards and then backwards over the line as fast as you can for 20 seconds. Repeat for the other foot.
- Stand on your right foot next to a line on the floor. Jump from side to side over the line as fast as you can for 20 seconds.

9. CONE DRILLS

- For these drill you can use cones or any kind of marker on the ground.
- The markers should be positioned 2 yards apart from each other.
- There are five different exercises in this drill:
 - a. Lateral Shuffle Forward
 - b. Forwards and Backwards
 - c. Lateral Shuffle Backwards
 - d. Back Peddle and Sprint
 - e. Up and Over (Go to your left and right)

Lateral Shuffle Forward

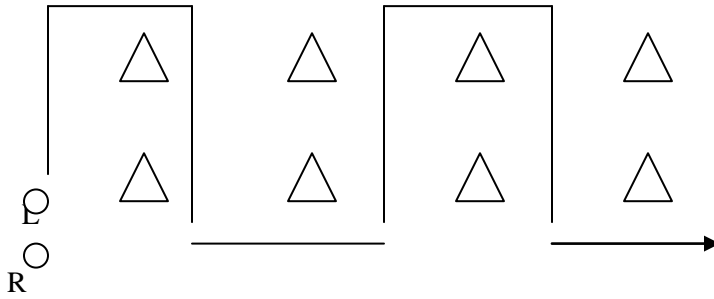

Forwards and Backwards

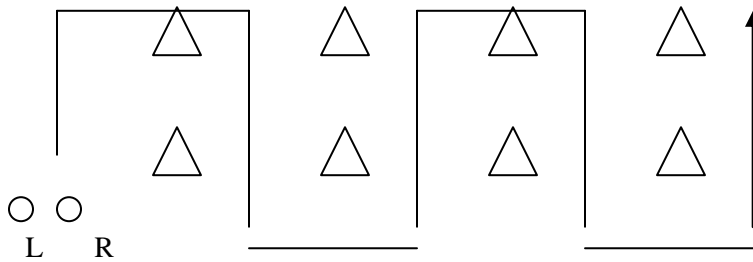

Lateral Shuffle Backwards

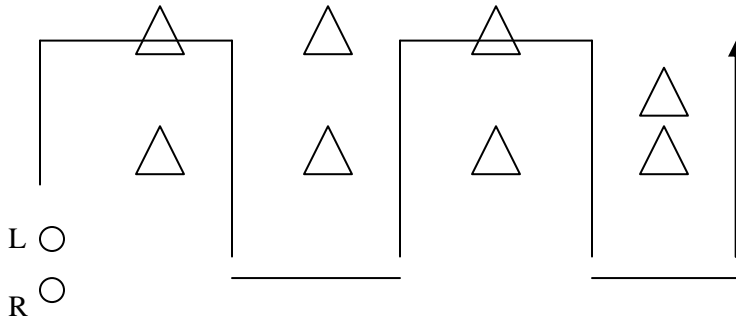

Back Peddle and Sprint

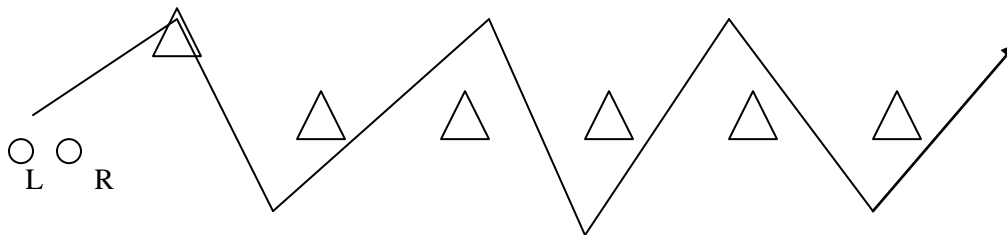

Up and Over

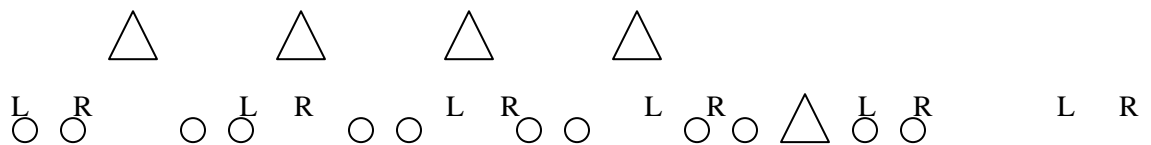

**NORSEMEN FOOTBALL
LIFT DESCRIPTIONS - BACK AND NECK LIFTS**

Chin Ups

Purpose: Develop biceps, lats, and middle back muscle strength.

Procedure: Hold the chin-up bar with a reverse grip (palms facing you) with your hands about 6 to 8 inches apart. Pull yourself up and try to touch either your chin or upper chest to the bar. Return slowly to the starting position. Do not swing back and forth.

Iso Neck Front and Back

Purpose: Develop neck muscle strength.

Procedure: You can perform this exercise seated or standing. Place your head and neck in a neutral position. Place both of your hands on the front side of your head and gently push for the required number of seconds on your workout. Resist any movement of your head by “isometrically” contracting your neck muscles. Repeat with your hands placed on the backside of your head.

Iso Neck Side to Side

Purpose: Develop neck muscle strength.

Procedure: You can perform this exercise seated or standing. Place your head and neck in a neutral position. Place your left hand on the left side of your head and gently push for the required number of seconds on your workout. Resist any movement of your head by “isometrically” contracting your neck muscles. Repeat with your right hand placed on the right side of your head

Lat Pull (Front)

Purpose: Develop lat, bicep, and middle back muscle strength.

Procedure: Start with feet flat on the floor. Grasp the wide bar firmly with an overhand grip. Your hands should be almost twice your shoulder width apart. Pull the bar down on top of your chest, arching your back slightly. Focus on keeping your elbows directly below the bar. Pause briefly with the bar in position right on top of your collarbone. Slowly raise the bar back to the starting position. Do not lean back to far and use your body weight to pull the weight down.

Lat Pull (Back)

Purpose: Develop lat, bicep, and middle back muscle strength.

Procedure: Start with feet flat on the floor. Grasp the wide bar firmly with an overhand grip. Your hands should be almost twice your shoulder width apart. Pull the bar down on top of your shoulders. Focus on keeping your elbows directly below the bar. Pause briefly with the bar in position right on top of your shoulders. Slowly raise the bar back to the starting position.

One Arm Row

Purpose: Develop middle back, bicep, and lat muscle strength.

Procedure: Begin with your right foot flat on the floor and your left knee resting flat on the bench. Then lean forward so that you are supporting the weight of your upper body with your left arm on the bench. Your back should almost be flat, almost parallel with the floor. Reach down and pick up a dumbbell with your right hand. Your left arm should be locked at the elbow so it will support the weight of your upper body. Before starting, look straight ahead instead of at the floor in order to keep your back straight. Tighten your abs to keep your body from turning to the side as you lift the dumbbell. Concentrate on pulling your elbow back as far as it can go. The dumbbell should end up roughly parallel with your torso. After you have rowed the dumbbell up as far as you can, slowly lower it to the starting position. Switch arms after one set.

Pull Ups

Purpose: Develop lat, bicep, and middle back muscles.

Procedure: Reach up and grab the bar with a firm overhand grip. Your hands should be roughly twice your shoulder width apart. This helps work more lats, rather than your biceps. Straighten your arms and let your body hang from the bar. You can keep your legs straight or bend your knees and cross your feet. Slowly pull your body up to the bar so that the top of your chest nearly touches the bar and your chin is over the bar. Try to keep your body straight without arching or swinging. As you move upwards, focus on pulling your elbows down at an angle toward your rib cage. Once your lats have completely contracted at the top, slowly lower your body to the starting position. On the last few reps, a spotter can lift your legs slightly if you need help on the last few reps.

NORSEMEN FOOTBALL LIFT DESCRIPTIONS - BICEP AND FOREARM LIFTS

Dumbbell Bicep Curl

Purpose: Develop bicep muscle strength.

Procedure: Stand straight up, with your head up and your legs straight. Start with the dumbbells at arm's length with your palms facing in. Curl dumbbells up at the same time, twisting your wrist on the way up. Your palms should be facing up when you are at the end of the movement. Do not swing and do not move your elbows. They should stay in the same place during the whole movement. Keep your arms close to your side.

Dumbbell Hammer Curl

Purpose: Develop bicep and forearm muscle strength.

Procedure: With a dumbbell in each hand, stand with your arms hanging at your sides, palms facing each other. Keep your elbows locked into your sides. Your upper body and elbows should remain in the same place during the whole lift. Keeping your palms facing each other, curl the weight in a semi-circle toward your shoulder. Squeeze the biceps hard at the top of the lift and then slowly lower. Do not turn your wrist during this lift.

Dumbbell Palms Down Wrist Curl

Purpose: Develop forearm muscle strength.

Procedure: Hold two dumbbells and sit at the end of a flat bench with your feet on the floor about 20 inches apart. Lean forward and place forearms on upper thighs, palms down. Place your wrist over your knees. Lower dumbbells as far as possible keeping a tight grip. Curl the dumbbell up as high as possible. Do not let your forearms move at all.

Dumbbell Palms Up Wrist Curl

Purpose: Develop forearm muscle strength.

Procedure: Hold two dumbbells and sit at the end of a flat bench with your feet on the floor about 20 inches apart. Lean forward and place forearms on upper thighs, palms up. Place the back of your wrist over your knees. Lower dumbbells as far as possible keeping a tight grip. Curl the dumbbell up as high as possible. Do not let your forearms move at all.

E-Z Bar Curl

Purpose: Develop biceps and forearm muscle strength.

Procedure: Take an E-Z curl bar and hold it on the innermost ridges. Your two hands together should be in the shape of a big V. While standing, hold the bar at arm's length in front of you. Curl the bar up while keeping your elbows in the same place. Do not swing. Contract your biceps as far as you can go, and then slowly return to the starting position.

Reverse Curl

Purpose: Develop forearms and bicep muscle strength.

Procedure: Grasp bar with a shoulder width overhand grip. With the elbows to the side, raise the bar until your forearms are vertical. Lower until the arms are fully extended. When the elbow is fully flexed, the elbow should only travel forward a few inches allowing the forearm to be no more than perpendicular with the floor to allow for a relative release of tension between repetitions.

Straight Bar Curl

Purpose: Develop bicep and forearm muscle strength.

Procedure: With your hands shoulder width apart, grip a barbell with an underneath grip. Stand straight up with your shoulders squared and with your feet shoulder width apart. Let the bar hang down at arm's length in front of you, with your arms, shoulders and hands in a straight line. Without leaning back or swinging the weight, curl the bar up and toward your chest in an arc. Keep your elbows in the same place and close to your sides. Bring the weight up as high as you can and squeeze at the top. Lower the weight slowly, resisting all the way down until your arms are nearly straight.

NORSEMEN FOOTBALL LIFT DESCRIPTIONS - CHEST LIFTS

Bar Bench

Purpose: Develop chest, triceps, and shoulder muscle strength.

Procedure: Same as regular bench press with the exception that you continue with the exercise until total exhaustion. The exercise will be complete when the spotter has to take the bar from your chest.

Bench Press

Purpose: Develop chest, triceps, and shoulder muscle strength.

Procedure: Lie face up on a flat bench; make sure feet are flat on the ground and back is slightly arched. Pull your shoulder blades inward as you push your chest upward. Grip the bar so your triceps are parallel to the floor there is a 90 degree angle in the elbow. Position yourself so the bar lines up with the top of your head. Take the bar from the rack with the aid of a spotter and position the bar over your chest. Take a deep breath, hold your chest high, and lower the bar to your chest in a slow, controlled movement. Allow the bar to just touch the chest at about nipple level. Drive the bar explosively off the chest so that the movement of the bar is up and slightly back. Exhale as you lock the bar out to full arm's length.

Close Grip Bench Press

Purpose: Develop chest, triceps, and shoulder muscle strength.

Procedure: Lie on a flat bench. Hold a barbell with both hands with a close grip, about 8 - 12 inches apart. Keeping your arms close to your sides, lower the bar until it touches your chest, approximately 1 inch below your nipples. Return to starting position, concentrating on using your triceps to push.

Close Grip Incline Bench Press

Purpose: Develop chest, triceps, and shoulder muscle strength.

Procedure: Lie on an incline bench. Hold a barbell with both hands with a close grip, about 8 - 12 inches apart. Keeping your arms close to your sides, lower the bar until it touches your chest, approximately 1 inch below your nipples. Return to starting position, concentrating on using your triceps to push.

Dumbbell Bench Press

Purpose: Develop chest, triceps, and shoulder muscle strength.

Procedure: Sit on the edge of a flat bench with dumbbells on your knees. In one smooth motion, roll onto your back while bringing the dumbbells up to a position slightly outside and above your shoulders. Your palm should face forwards. Bend your elbows at a 90 degree angle so that your upper arms are parallel to the ground. Press the weights up over your chest in a triangular motion until they meet above the centerline of your body. As you lift, concentrate on keeping the weights balanced and under control. Then, follow the same path downward until your arms are slightly below parallel to the floor.

Dumbbell Incline Bench Press

Purpose: Develop chest, triceps, and shoulder muscle strength.

Procedure: Sit on the edge of an incline bench set at about a 45 degree angle. Pick up a dumbbell in each hand and place them on your thighs. Then, one at a time, raise them to your shoulder level while you press your back and shoulders firmly against the bench. Press the weights back up to a point over your upper chest, with your palms facing forward. Lower the weights slowly. Inhale as you lower the weights and exhale as you lift.

Incline Bench Press

Purpose: Develop chest, triceps, and shoulder muscle strength.

Procedure: Lie flat on an incline bench with feet flat on the floor. Grasp the bar with a bench press grip. Take a deep breath, hold your chest high, and lower the bar to your chest in a slow, controlled movement. Allow the bar to just touch your chest at the collar bone level. Drive the bar explosively off the chest so that the movement of the bar is up and slightly back. Exhale as you lock the bar out to full arm's length.

Negative Bench Press

Purpose: Develop chest, triceps, and shoulder strength.

Procedure: Same as bench press with the exception that you are trying to resist the weight as it comes down to your chest for a five count. Your spotter will help with you return the weight to the starting position.

NORSEMEN FOOTBALL
LIFT DESCRIPTIONS - LEG AND BODY LIFTS

Ankle Circles

Purpose: Develop ankle joint strength and stabilization.

Procedure: Stand on one foot and draw circles clockwise and counter clockwise with your big toe.

Back Squat

Purpose: Develop quadriceps, hamstrings, glutes, and calf muscle strength.

Procedure: With the bar chest high on the racks, position hands slightly wider than shoulder width. Step under the bar, keeping feet parallel, knees slightly bent, and hips vertically aligned with your shoulders. Place bar comfortably across the top of the shoulders at the base of the neck, or one inch below the top of the shoulders across the traps. Pull your shoulder blades together tightly and lift the bar out of the rack by extending the knees. Step backward, using as few steps as possible, with feet parallel. Point toes out somewhat and keep heels on the floor slightly wider than the hips. Focus your eyes on the wall with head slightly up; take a deep breath. In a slow and controlled motion, lower the bar by bending your hips and knees and keeping your knees out in alignment with the feet. The instant the tops of your thighs are parallel to the floor, explode up from the bottom. Keep your back flat, weight on your heels, and shoulder blades drawn together. Do not throw your head back. Fully extend your knees and hips and exhale as you near the completion of the lift.

Barbell Overhead Lunge

Purpose: Develop quadriceps, hamstrings, glutes, and calf muscle strength.

Procedure: Place a barbell on your upper back. Lift your chest up and look straight ahead. Position your right leg forward in a long stride. Your foot should be far enough in front of you so that when you bend your right knee, your thigh and lower leg form a right angle. Slowly bend your knees, lowering your hips so your rear knee just clears the floor. Pause briefly in this position, then slowly straighten your legs and raise your body back up to a standing position. Complete a full set, then switch legs and repeat, or alternate legs for each rep. Make sure your knee does not travel past your toes in the down position.

Deadlift

Purpose: Develop quadriceps, hamstrings, glutes, and calf muscle strength.

Procedure: Place feet hip width apart, with toes pointed slightly out. Bend knees with the lower leg touching the bar. Grasp the bar using an overhand grip with arms extended and hands shoulder width apart. Stand upright with the bar by extending the legs and hips, and let the bar rest on the thighs. Fill the chest with air and hold high. In a slow controlled motion, lower the bar as far as possible by bending at the hips and knees. Do not bounce the weight off the ground. Reverse directions and pull the bar to a point just above the knees, tracing the bar over the shin and knee cap.

Dorsi Flexion

Purpose: Develop calf muscle strength.

Procedure: Sit on a flat bench with your heels on the edge. Your toes should point straight out in front of you. Your lifting partner should apply pressure on your toes as you move your toes back to point at you. Return to starting position and repeat.

Dumbbell Front Lunge

Purpose: Develop quadriceps, hamstring, glutes, and calf muscle strength.

Procedure: Hold a dumbbell in each hand and pull your shoulders back. Lift your chest up and look straight ahead. Position your right leg forward in a long stride. Your foot should be far enough in front of you so that when you bend your right knee, your thigh and lower leg form a right angle. Slowly bend your knees, lowering your hips so your rear knee just clears the floor. Pause briefly in this position, then slowly straighten your legs and raise your body back up to a standing position and then repeat with other leg. Make sure your knee does not travel past your toes in the down position.

Dumbbell Lateral Lunge

Purpose: Develop quadriceps, hamstring, glutes, and calf muscle strength.

Procedure: Hold a dumbbell in each hand and pull your shoulders back. Lift your chest up and look straight ahead. Sink slightly and take a lateral side step, bending with the lead leg while extending the opposite leg. Keep your back flat and your lower back slightly arched at all times. Extend your lead leg to return to starting position.

Dumbbell Step Ups

Purpose: Develop quadriceps, hamstring, glutes, and calf muscle strength.

Procedure: Hold two dumbbells, one in each hand, at your side. Step up onto a flat bench with your left leg. Then step up with your right leg so you are now standing on the bench. Step down with your left leg, then your right leg. Repeat, starting with your right leg this time.

Front Squat

Purpose: Develop quadriceps, hamstring, and calf muscle strength.

Procedure: Place a barbell on your upper chest and rest it on your shoulders. Place your hands shoulder width apart in an overhand grip. Point your elbows up past parallel. Keep your head up and back straight with a shoulder width stance. Your toes and knees should be slightly pointed outwards. Squat down until your upper thighs are parallel to the floor. Return slowly to the starting position.

Hang Clean

Purpose: Develop shoulder, triceps, middle back, traps, forearms, quadriceps, hamstring, glutes, and calf muscle strength.

Procedure: Start with feet slightly wider than shoulder width apart and pointed slightly out. Knees slightly bent and relaxed, bend forward at the hips while keeping back flat. The chest should be out, elbows straight, and relaxed, and shoulders back. You should be holding the bar at thigh or knee level with an overhand grip hip width apart. Explosively extend the hips in a scooping action while simultaneously extending up on the balls of your feet and shrugging your shoulders. Keep the bar close to your body and your elbows should stay high. As the bar is moving upward, pull yourself down under the bar by bending at your ankles, knees, and hips. Rotate your elbows around and under the bar and your elbows should point directly in front of you. Rack or catch the bar across the front of your shoulders. Keep the torso erect, feet flat on the ground and bend at the ankles, knees, and hips to absorb the weight of the bar. Return the bar to the starting position on the front of your thigh for the next rep. Remember to keep your torso erect and bend at the hips.

One Leg Squat

Purpose: Develop quadriceps, hamstring, glutes, and calf muscle strength.

Procedure: On one leg squat down to the point where your thigh is parallel with the floor. Then, drive up to the starting point. This lift may be done with a hand on a squat rack for balance.

Overhead Squat

Purpose: Develop quadriceps, lower back, hamstring, glutes, shoulder, and calf strength.

Procedure: Place the bar overhead with a overhand grip at the edge of the bar. Lock your elbows out; this should rest the bar behind your head. Your base should be wide with knees and toes pointing slightly outward. Squat by lowering hips between your heels until your upper legs are below parallel with the floor. Maintain an upright posture with back tight and chest up. Keep feet flat on the floor and maintain eyes straight ahead. Do not lean forward from the waist and push hips back.

Power Clean

Purpose: Develop shoulder, triceps, middle back, traps, forearms, quadriceps, hamstring, glutes, and calf muscle strength.

Procedure: Start with feet hip width apart and flat on the floor. Bend legs with the lower leg touching the bar and hips slightly higher than knees. Use overhand grip with hands placed shoulder width apart. Extend arms with elbows pointed out. Inhale to fill chest with air and hold it high. Keep back flat with lower back slightly arched. Position shoulders just ahead of bar and set head in a comfortable position. On the first pull extend your legs elevating the bar to just above the knees, keeping the angle of your back constant. Do not jerk the bar off the floor; pull it smoothly and under control. Keep the bar close to your legs and your arms extended with elbows pointed out. Second pull extend your hips up and forward explosively. If you keep your arms straight, (elbows pointed out) your knees will automatically flex or rebind as the hips extend. The bar should ride up the thighs. Explosive phase extend onto the balls of your feet while simultaneously shrugging your shoulders. Your ankles, knees, and hips should extend simultaneously, accelerating the bar upward. Keep the bar close to your body and your arms extended with elbows pointing out. In the receiving of the bar, you should pull yourself down and under the bar. Elevate the feet and move them out into a squatting stance, do not let your feet get too wide. Rotate your elbows down and then up ahead of the bar into the racked position. Catch the bar on the front portion of the shoulders. Flex your knees and hips to absorb the weight bar. Once the catch is made, you should be able to finish the lift with a front squat.

Seated One Leg Calf Raises

Purpose: Develop calf muscle strength.

Procedure: Place a block on the floor about 12 inches from a flat bench. Sit on the bench and rest a dumbbell on your upper thigh about 3 inches above your knee. Place the ball of your foot on the block. Raise your toes up as high as possible. Squeeze your calf muscle, and then return to the starting position, stretching as far down as possible.

Straight Leg Deadlift

Purpose: Develop hamstring, glutes, and calf muscle strength.

Procedure: Bend at your waist with your head up, back straight and knees nearly locked on top of a flat bench or a plyo box. Hold bar with hands about 16 inches apart. Straighten up while holding the bar at arm's length. Lower back down to the floor but do not let plates touch.

NORSEMEN FOOTBALL
LIFT DESCRIPTIONS - SHOULDER LIFTS

Bent Over Row

Purpose: Develop middle back, lats, and bicep muscle strength.

Procedure: Position your feet shoulder width apart. Bend over so your back is as close to parallel to the floor as you can and hold bar with an overhand grip and with the hands a little wider than shoulder width. Keep legs slightly bent at the knee. Hold bar at arm's length straight down. Pull bar straight up to the lower part of the chest. Slowly lower the bar back to the starting position. Keep your head up and back straight at all times, and do not swing or use momentum of the weight.

Dumbbell Front Raises

Purpose: Develop shoulder muscle strength.

Procedure: Stand with a dumbbell in each hand, palms facing backward. Your feet should be about shoulder width apart. Maintain a slight bend in your elbows throughout the exercise so that your arms are straight, but not quite locked. Lift both dumbbells in front of you in a wide arc until it is slightly higher than shoulder height. With a smooth, controlled motion, lower the weight. Do not swing your body or lean backwards.

Dumbbell Lateral Raises

Purpose: Develop shoulder muscle strength.

Procedure: Stand upright, with your feet about shoulder width apart and your arms to your sides. Hold a dumbbell in each hand, with your palms turned toward your body. Keeping your arms straight, lift the weights out and up to the side until they are slightly higher than shoulder level. Then slowly lower them to your sides. Keep the palms turned downward as you lift the dumbbells so that your shoulders, rather than your biceps do the work. Don't lean forward and lift the weight on the way up rather than swinging the weight up.

Push Press

Purpose: Develop shoulder and triceps muscle strength.

Procedure: Place the bar in a racked position, as if you had just caught a power clean. Grip the bar just outside the shoulders. Your feet should be shoulder width. Flex the knees and hips; lower your body to quarter squat position. Extend explosively onto the balls of the feet. Keep your body under the bar during the explosive phase. Drop the bar by splitting your feet and landing in a position with one foot in front and the other behind. Both legs should be bent at the knee joint. Recover by taking short steps until both feet are back in the starting position. Once feet are under you, lower the bar back to the racked position. Bend knees and hips to absorb the weight as it comes down. Make sure that you rotate which foot you lead with.

Seated Military Press

Purpose: Develop shoulder and triceps muscle strength.

Procedure: Grip the bar with a bench press grip. Place the bar behind the neck on the shoulders while sitting on a flat bench with feet on the floor. Press the bar overhead by extending the arms. Lower the bar until it reaches a position of just below the ears and drive the bar up to starting position.

Shoulder Shrug

Purpose: Develop trap and forearm muscle strength.

Procedure: Hold a barbell with both hands in front of you with your hands a little wider than shoulder width apart in an overhand grip. Keep your feet at shoulder width. Stand straight up with the bar hanging at arms length. Droop shoulders down as much as possible to start. Raise your shoulders up as far as you can go.

Standing Palms In Dumbbell Press

Purpose: Develop shoulder and triceps muscle strength.

Procedure: Raise two dumbbells to shoulder height. Lock legs and hips. Keep your elbows in and your palms facing in. Press dumbbells to shoulder height. Return slowly to starting position.

Up Right Row

Purpose: Develop shoulder, bicep, and trap muscle strength.

Procedure: Standing upright, grasp a barbell with your hands shoulder width apart. Let the bar hang straight down in front of you. Keep your body and wrist straight. Pull the bar towards your chin, keeping it close to your body. Concentrate on either pulling with your traps or the front of your shoulders, depending on what you want to work most. Lower the weight slowly to the starting position. Do not lean forward or back completing the lift.

NORSEMEN FOOTBALL LIFT DESCRIPTIONS - TRICEPS LIFTS

Dumbbell Triceps Extension

Purpose: Develop triceps muscle strength.

Procedure: Sit on the end of a flat bench with head held high and feet on floor. Hold a dumbbell with both hands at the end, raise overhead to arm's length. Your palms should be facing up and gripping the dumbbell around the top plate. Keep your arms close to your head and your elbows in the same place during the entire movement. Lower dumbbell in a semicircular motion behind your head until your forearms touch your biceps and return to starting position.

Skull Crushers

Purpose: Develop triceps muscle strength.

Procedure: Sit on a flat bench holding an E-Z curl bar with an overhand grip. Lie back so that the top of your head is even with the end of the bench. At the same time, extend your arms over your head so that the bar is directly over your eyes. Keep your elbows tight and your upper arms stationary throughout the exercise. Holding your upper arms in a fixed position, slowly lower the bar until it almost touches your forehead. Then press the bar back in a slow, sweeping arc motion, locking elbows out at the end of the lift.

Triceps Pushdown

Purpose: Develop triceps muscle strength.

Procedure: Using a high-cable pulley, grasp a short V bar with an overhand grip. Your hands should be about 10 inches apart. Position your forearms so they are parallel to the floor. Keep your feet shoulder width apart and bend your knees slightly. Keep your elbows locked in close to your body and your wrists straight. Keep your whole body steady, push the bar down as far as possible towards your legs, locking your arms and feeling the triceps full contract. Keep the upper arms close to the body. Return to the starting position using the same motion. Never move your elbows or torso. Stay standing straight up.

NORSEMEN FOOTBALL CORE TRAINING EXERCISES

ABDOMINALS SERIES

Crunch: Lie on back with feet on ground with arms across the chest. Place chin on your chest while lifting your head six to eight inches off the ground and hold for one second.

Bicycle Crunch: Lie on your back with your knees bent and feet off the ground. Simultaneously bring right knee back towards you chest and bring your left elbow down to your knee. Then straighten out the right knee and return upper body to start position. Bring left knee up towards chest and bring right elbow down to your knee.

Leg Raises: Lie on your back with arms folded across your chest. Raise your feet six inches off the ground and hold for the prescribed amount of time.

Full/Up/Half/Up: Start in the up position of a full sit up with arm folded across your chest. Go down until you shoulders touch the ground. Return to the start position. Go down halfway between the ground and the start position. Return to the start position.

Full Sit Up: Start sitting on butt with feet on the ground and arms folded across your chest. Lower upper body so that shoulders touch the ground. Return to the starting position.

Half Sit Up: Start in the up position of a full sit up with arms folded across your chest. Lower your upper body to a point halfway between the ground and the starting position. Return to the starting position.

Two Knee Up: Lie on your back with arms folded across your chest and feet six inches off the ground. Bring both knees up towards your chest and hold for one second and return to starting position.

Heel Twist: Lie on your back with feet on the ground and arms at your side. Keep shoulder blades six inches off the ground. Reach with right hand in between heels and butt and touch left foot. Return to starting position. Reach with left hand in between heels and butt and touch right foot. Return to starting position.

Rope Climb: Lie on your back with feet straight up in the air and crossed. Lift up your chest and reach right hand to left toe and left hand to right toe.

Leg Over: Lie on your back with knees locked and feet over to the right side. Bring feet up and over to the left side and return to the right side without touching the ground.

One Knee Up: Lie on your back with feet six inches off the ground and arms folded across your chest. Bring the right knee up to your chest, return it to starting point, and repeat with left leg.

Half Twist: Start sitting on butt with feet on the ground and arms at the side of your head. Lower upper body to the point halfway between the ground and starting position. Bring upper body back to starting position and twist so that right elbow touches left knee. Return to halfway point. Bring upper body back to starting point and twist so that the left elbow touches the right knee.

PUSH UP SERIES

Push Up: Start with back flat, leg locked, and body six inches off the ground. Your arms should be no wider than shoulder width apart. Push to the up position so that arms are full extended and return to the starting position.

Clap Push Up: from the push up start, position explode and push your body up. Clap your hands and recover them into position for the catch at the bottom.

Diamond Push Up: You should be in a push up starting position, but your hands should be positioned so that your thumbs are touching and so are your pointer fingers (making the diamond). Push to the up position and return to the starting position.

BACK SERIES

Superman: Lie on your stomach with arms and legs positioned straight out from your body. Raise as much of your body off the ground as possible and hold for five seconds, lower your body, and repeat for the prescribed number of repetitions.

Opposite Superman: From the superman starting position, raise your right arm and left leg getting as much of your body off the ground as possible for a five count. Return to the starting position. Raise your left arm and right leg getting as much of your body off the ground as possible for a five count. Repeat for the prescribed number of repetitions.

Push Up Superman: From the up position of a push up, raise your right arm and left leg off the ground so that they are even with your body for a five count. Lower to start position. Raise left arm and right leg off the ground so that they are even with your body for a five count. Repeat for the prescribed number of repetitions.

HIPS SERIES

Forward Hurdles: Set up hurdles so that they alternate between the highest possible setting and the lowest possible setting. Facing forward go over the low hurdles and under the high hurdles. Bend at the hips not at the waist while doing this.

Backward Hurdles: Set up hurdles so that they alternate between the highest possible setting and the lowest possible setting. Bend at the hips not at the waist while doing this. Walk through the hurdles going over the low hurdles and under the high hurdles.

Left Hurdles: Set up hurdles so that they alternate between the highest possible setting and the lowest possible setting. Bend at the hips not at the waist while doing this. Face so that you are going to your left and go over the low hurdles and under the high hurdles.

Right Hurdles: Set up hurdles so that they alternate between the highest possible setting and the lowest possible setting. Bend at the hips not at the waist while doing this. Face so that you are going to your right and go over the low hurdles and under the high hurdles.

Wall Sit: Position yourself with back flat against a wall in a position where your thighs are parallel to the ground. Hold for the prescribed amount of time.

**NORSEMEN FOOTBALL
SUMMER STRENGTH & CONDITIONING
MAY 2009**

Sun	Mon	Tue	Wed	Thu	Fri	Sat
					1 <i><u>3 Months</u></i> <i><u>until fall</u></i> <i><u>camp</u></i>	2
3	4 <i>Weight Testing</i>	5 <i>Weight Testing</i>	6 <i>Weight Testing</i>	7 <i>Weight Testing</i>	8 <i>Off</i> <i>Finals</i>	9 <i>Off</i>
10 <i>Off</i>	11 <i>Off</i> <i>Physicals</i> <i>Finals</i>	12 <i>Off</i> <i>Physicals</i> <i>Finals</i>	13 <i>Off</i> <i>Finals</i> <i>Graduation</i>	14 <i>Off</i>	15 <i>Off</i>	16 <i>Off</i>
17 <i>Off</i> <i><u>Week 1</u></i>	18 <i>Workout #1</i>	19 <i>Workout #2</i>	20 <i>Off</i>	21 <i>Workout #3</i>	22 <i>Workout #4</i>	23 <i>Off</i>
24 <i>Off</i> <i><u>Week 2</u></i>	25 <i>Workout #5</i>	26 <i>Workout #6</i>	27 <i>Off</i>	28 <i>Workout #7</i>	29 <i>Workout #8</i>	30 <i>Off</i>

NORSEMEN FOOTBALL
SUMMER STRENGTH & CONDITIONING
JUNE 2009

Sun	Mon	Tue	Wed	Thu	Fri	Sat
31 <i>Off</i> <u>Week 3</u>	1 <i>Workout #9</i> <u>2 Months</u> <u>until fall</u> <u>camp</u> <i>Summer</i> <i>School Starts</i>	2 <i>Workout</i> <i>#10</i>	3 <i>Off</i>	4 <i>Workout</i> <i>#11</i>	5 <i>Workout</i> <i>#12</i>	6 <i>Off</i>
7 <i>Off</i> <u>Week 4</u>	8 <i>Workout</i> <i>#13</i>	9 <i>Workout</i> <i>#14</i>	10 <i>Off</i>	11 <i>Workout</i> <i>#15</i>	12 <i>Workout</i> <i>#16</i>	13 <i>Off</i>
14 <i>Off</i> <u>Week 5</u>	15 <i>Workout</i> <i>#17</i>	16 <i>Workout</i> <i>#18</i>	17 <i>Off</i>	18 <i>Workout</i> <i>#19</i>	19 <i>Workout</i> <i>#20</i>	20 <i>Off</i>
21 <i>Off</i> <u>Week 6</u>	22 <i>Workout</i> <i>#21</i>	23 <i>Workout</i> <i>#22</i>	24 <i>Off</i>	25 <i>Workout</i> <i>#23</i>	26 <i>Workout</i> <i>#24</i>	27 <i>Off</i>
28 <i>Off</i> <u>Week 7</u>	29 <i>Workout</i> <i>#25</i>	30 <i>Workout</i> <i>#26</i>				

**NORSEMEN FOOTBALL
SUMMER STRENGTH & CONDITIONING
JULY 2009**

Sun	Mon	Tue	Wed	Thu	Fri	Sat
<u>Week 7</u>			1 Off <u>1 Month until fall camp</u>	2 Workout #27	3 Workout #28	4 Off
5 Off <u>Week 8</u>	6 Workout #29	7 Workout #30	8 Off	9 Workout #31	10 Workout #32	11 Off
12 Off <u>Week 9</u>	13 Workout #33	14 Workout #34	15 Off	16 Workout #35	17 Workout #36	18 Off
19 Off <u>Week 10</u>	20 Workout #37	21 Workout #38	22 Off	23 Workout #39	24 Workout #40 <i>Summer School Ends</i>	25 Off
26 Off <u>Week 11</u>	27 Workout #41	28 Workout #42	29 Off	30 Off	31 Off	

**NORSEMEN FOOTBALL
SUMMER STRENGTH & CONDITIONING
AUGUST 2009**

Sun	Mon	Tue	Wed	Thu	Fri	Sat
						1 Football Check In
2 Football Check In -Meeting 3:00	3 Bowling	4 Camp Warren	5 Physical Testing	6 Physical Testing	7 Prac #1	8 Prac #2
9 Prac #3	10 Prac #4 Prac #5	11 Prac #6	12 Prac #7 Prac #8	13 Prac #9	14 Prac #10 Prac #11	15 Prac #12 Scrim #1
16 Prac #13	17 Prac #14 Prac #15	18 Prac #16	19 Prac #17 Prac #18	20 Prac #19	21 Prac #20 Prac #21	22 Prac #22 Scrim #2
23 Prac #23	24 Prac #24 Fall Semester Begins	25 Prac #25	26 Prac #26	27 Prac #27	28 Prac #28	29 MSCTC @ SCSU 1:00

NORSEMEN FOOTBALL PLYOMETRIC EXERCISES

1. JUMP TUCKS

Start in a standing position with feet shoulder width apart. Bend at the ankles, knees, and hips. Explode vertically and pull knees high to chest. Drive the arms in an upward motion. Land on the balls of the feet, in the starting position and repeat. Do not stay on the ground; you want to explode again as quickly as possible.

2. BOUND FOR HEIGHT

Start in a standing position with feet shoulder width apart. Bend at the ankles, knees, and hips. Explode vertically and horizontally. Pull knees high to the chest. Drive arms in an upward motion. Land on the balls of the feet, in the starting position and repeat. Do not stay on the ground. Spend as a little time on the ground as possible.

3. BOUND FOR DISTANCE

Start in a standing position with feet shoulder width apart. Bend at the ankles, knees, and hips. Explode horizontally. Pull the knees through and to the chest. Drive the arms in an upward motion. Land on the balls of the feet, in the same starting position and repeat. Do not stay on the ground. Spend as little time on the ground as possible.

4. 1 LEG HOP

Start in a standing position on one leg. Bend at the ankles, knees, and hips. Explode vertically and horizontally. Drive arms in an upward motion. Land on the ball of your foot, in the same starting position and repeat.

5. POWER SKIPPING

Begin skipping, pushing off explosively with the back leg. Opposite leg drives knee up as high as possible, trying to achieve maximum height and distance. Drive knee to chest and use sprinting arm action. Prepare for contact with the ground and repeat with the opposite leg immediately upon landing.

NORSEMEN FOOTBALL CONDITIONING DRILLS

1. V SPRINT

Set up a "V" shaped course. Each marker should be set 20 yards apart. Start at one side of the "V" shaped course. Accelerate to and around the center cone. Decelerate as you approach the center cone. Drop your hips bringing your body under control. Plant on the outside foot, change direction, and accelerate to the third cone.

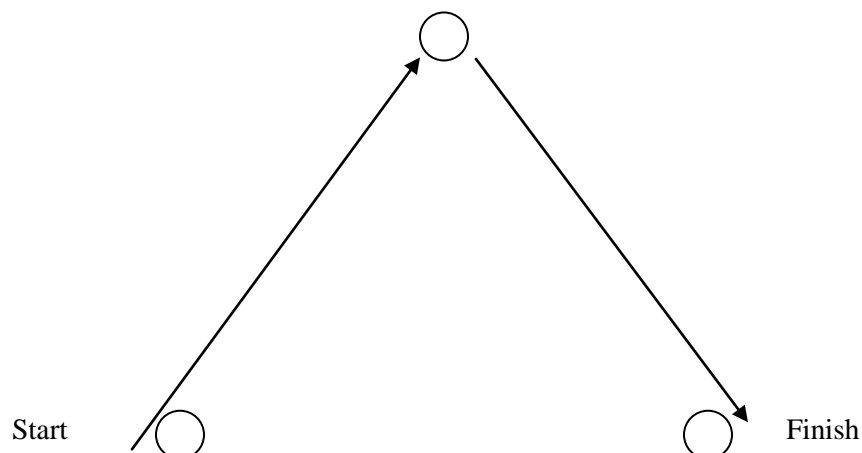

2. U SPRINT

Set up a "U" shaped course. Each marker should be 20 yards apart. Start at one side of the "U" shaped course. Accelerate to and around the center cones. Decelerate as you approach the curve. Drop your hips keeping your body under control. Accelerate through the other side of the "U" course.

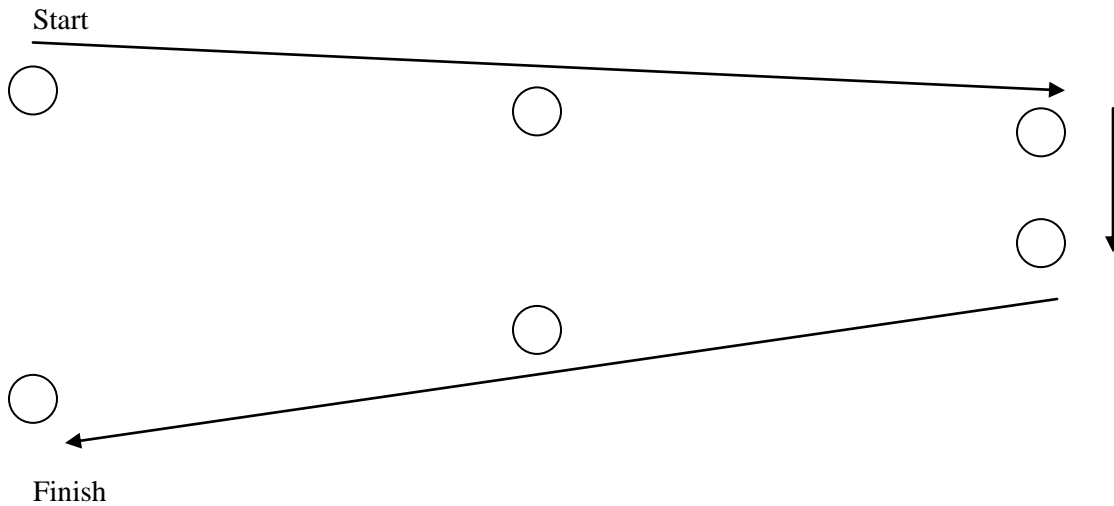

3. N SPRINT

Set up a "N" shaped course. Each marker should be 20 yards apart. Start at one side of the "N" shaped course. Accelerate to and around the first far cone. Decelerate as you approach the cone. Drop your hips bringing your body under control. Plant on the outside foot, change direction, and accelerate to the next cone. Decelerate as you approach the cone. Drop your hips bringing your body under control. Go around the final cone and accelerate to the final cone.

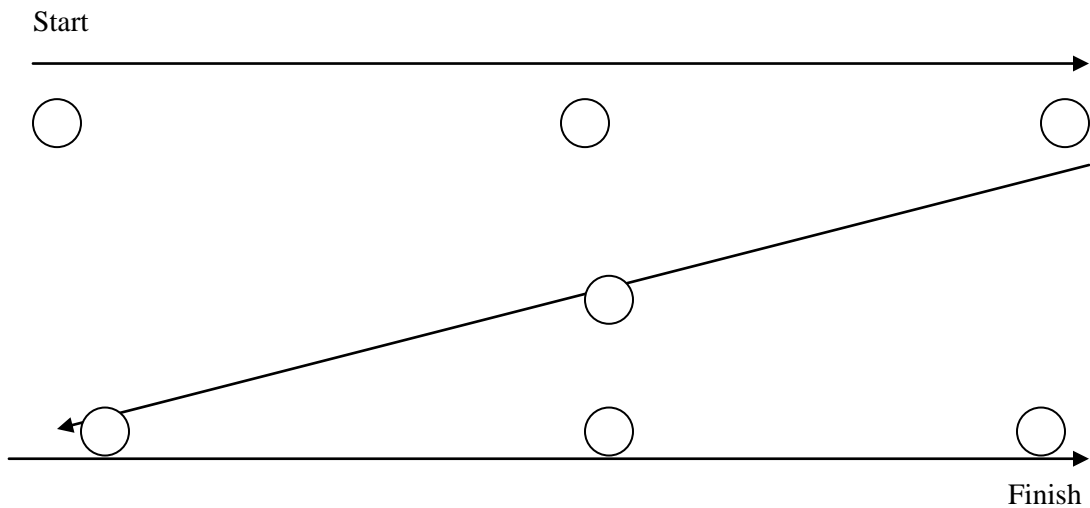

4. LADDER

This is a sprint ladder that should be completed with a 30 second rest every time the distance changes.

Set #1...10-10 yard sprints

Set #2...9-20 yard sprints

Set #3...8-30 yard sprints

Set #4...7-40 yard sprints

Set #5...6-50 yard sprints

Set #6...5-60 yard sprints

Set #7...4-70 yard sprints

Set #8...3-80 yard sprints

Set #9...2-90 yard sprints

Set #10...1-100 yard sprint

5. GASSER

Sprint sideline to sideline on a standard football field. Start on one sideline, sprint to the other sideline and return to the same sideline you started from as fast as possible. Two reps count as one.

6. 350 X 5

Run all the way around the outside of a football field (5X). One time around equals one rep (350 yards). Time yourself during each run. Take a 30 second recovery between reps. Goal times are based on body weight. If you way over 230 pounds you should make it in under 70 seconds. If you way under 230 pounds you should make it in under 60 seconds.

NORSEMEN FOOTBALL STRENGTH PROGRAM & TESTING PHILOSOPHY

PHILOSOPHY & TESTING

The Mesabi Range College Football Summer Manual has been developed to provide Norsemen players with a step-by step summer strength and conditioning program to enhance each player's athletic ability and achieve maximum results.

GOALS

The goals of the Summer Program are to:

1. Increase speed and power
2. Increase strength and flexibility
3. Increase agility and quickness
4. Increase overall conditioning
5. Improve position skills
6. Increase mental toughness:
 - a. Discipline
 - b. Competitiveness
 - c. Mental stamina

WARM-UP

The warm up period is important because it prepares the athlete for the upcoming workout. The athlete needs to perform a light activity for eight to ten minutes to elevate the body temperature and to break a light sweat prior to beginning the main workout. Warming up protects the athlete from potential injury. Follow the warm up drills prescribed in this manual.

STRETCH

The stretch period has two main purposes. The first is to prepare the athlete for the upcoming workout and to prevent injury to the athlete during the workout. Secondly, by performing the prescribed stretching exercises the athlete will increase his level of flexibility over the course of the program.

STRENGTH

The strength program is a four day split routine program specifically designed for the individual player. Each athlete will have a program designed to improve strength through free weight exercises and his explosive power through Olympic and speed strength movements.

POWER

We will use a variety of different methods and exercises to develop explosiveness in the weight room and on the field. The main focus of these exercises is to develop the ability to generate force quickly. We want to develop explosiveness in the muscles that are responsible for the movement on the football field. This type of training develops the neuromuscular system so that the athlete is able to accelerate more quickly, jump higher, hit harder, run faster, etc. These drills make it possible for the football player to use the strength he has developed out on the playing field.

CONDITIONING

The athlete must be fast, strong, and in the best overall condition when reporting for camp in August. The level of conditioning reached by each player is important. The game of football is anaerobic (high intensity, short duration activities). Our program will allow us to be conditioned for football. The anaerobic capacity will increase steadily through a continuous overload, using several sprint and football specific movements. It is critical that you follow the daily conditioning workouts, as they are designed to prepare you for the rigors of preseason practices.

FALL CAMP TESTING

Our first practice in August will consist of eight various test. You will be tested individually and your performance will give the coaches data, which will be used to evaluate your summer activities. These test results are also what the coaches send to college across the country and are what these coaches use to evaluate you. We have designed the summer program so that you will be in the best condition possible for all the components that we will test. For success to be achieved, it is imperative that you follow your summer program as outlined. Through out the summer give your best effort so you can plan to contribute to this year's success.

Below are the physical performances that you will be tested in:

1. Height
2. Weight
3. Vertical Jump
4. Pro Agility
5. 40
6. Bench Press
7. Squat
8. Power Clean

TESTING PROTOCOL

VERTICAL JUMP

Procedure:

Reach

- Stand directly under the marking tape with both feet flat on the ground.
- Athlete then reaches directly above as high as possible.

Jump

- Position yourself under the marking tape.
- Jump, placing touching the highest point on the tape.
- Athlete is allowed two trials.

PRO AGILITY

Procedure:

- From a three-point stance straddle line 1 facing timer.
- Start by running to the right to line 2.
- Touch line 2 with right hand.
- Sprint back across line 1 to line 3 to the left.
- Touch line 3 with left hand.
- Turn and sprint through line 1.
- The timer will start the clock on the athlete's first movement.
- Athlete is allowed two trials.

Causes for disqualification:

- Not touching line 2 with right hand.
- Not touching line 3 with left hand.

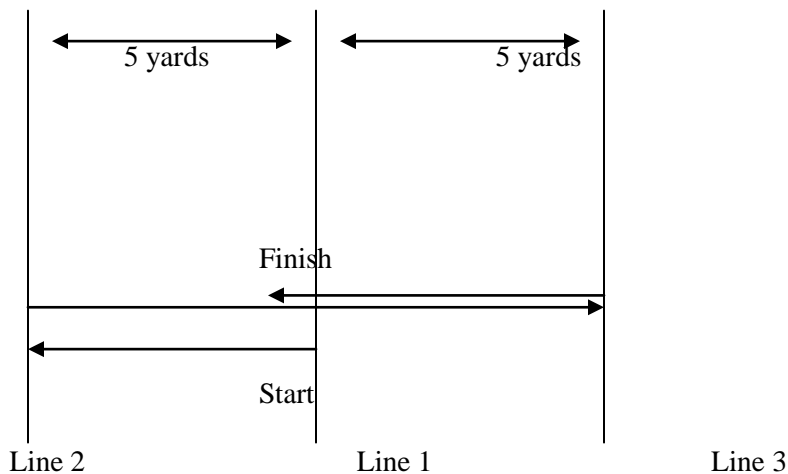

BENCH PRESS

Procedure:

- Athlete will perform a maximum effort (1 rep) lift on the bench press.
- Lift will start with bar over the chest and arms locked out.
- Bar must touch, but not bounce off the chest.
- Hips must remain on the bench.
- Elbows must reach a locked position.
- Disqualification will occur if there is any outside influence touching the bar (the power rack or spotter).
- Athlete is allowed three recorded lifts.

SQUAT

Procedure:

- Athlete will perform a maximum effort (1 rep) lift parallel squat.
- Lift will start with bar resting on back.
- Weight must be lowered to a point where the thighs are parallel to the floor.
- Disqualification will occur if there is any outside interference touching the bar or lifter, or if the bar touches the rack.
- Athlete is allowed three recorded lifts.

POWER CLEAN

Procedure:

- Athlete will perform a maximum effort (1 rep) lift power clean.
- Lift will start with bar resting on the ground.
- Lift will end with bar racked on shoulder and lifter having control of the bar.
- Disqualification will occur if there is any outside interference touching the bar or lifter.
- Athlete is allowed three recorded lifts.

40 YARD SPRINT

Procedure:

- Athlete will perform maximum effort sprint for forty yards.
- Sprint will start with athlete in any stance they want behind the start line.
- Sprint will end when the athlete crosses the finish line.
- The timer will start the clock on the athlete's first movement.
- No cleated track shoes will be used.
- Athlete is allowed three solo attempts.

NORSEMEN FOOTBALL NUTRITION

Athletes often overlook proper nutrition during intense physical training and sports competition. Optimal nutrition will enhance an athlete's ability to perform at high levels. Poor nutrition habits and using "fad" nutritional supplements can lead to poor performance.

To be nutritionally successful, athletes must consume the right types and quantities of food at the right time and drink an abundance of water. Consuming too much or too little of certain food types can lead to decreased energy levels, poor workouts, increased body fat, decreased mobility, and illness/injury.

Fluid Replacement

Water is the most important nutrient for the athlete. Your body is made up of 75% water. Water is necessary for all metabolic functions within the body. As an athlete, a 2% weight loss of body water can affect performance and cause health problems. The thirst mechanism generally does not kick in until you have lost 3% of your body water. Body temperature increases with exercise and water works to cool the body. Dehydration can lead to heat illness, cramping, and eventually death.

It is recommended that you consume water before, during, and after workout or competition. You should drink:

- * 2 cups of water 2 hours before exercise
- * ½ cup of water every 10-15 minutes during exercise
- * 2 cups of water for every pound lost after exercise
- * In addition, consume 6-8 cups of water per day (1 gallon)
- * Add a small amount of lemon juice to your water for better taste

Sports drinks can be beneficial. Most are best for exercises lasting longer than 60 minutes. Avoid those with high sugar content. Choose those with 8-15 grams of carbohydrates per 8 ounces for best intestinal absorption.

The Right Balance of Nutrients

As an athlete, your nutritional demands are different than the general population. A typical American diet consists of 30% carbohydrates, 30% protein, and 40% Fat. As an athlete, you should consume 60% complex carbohydrates, 15% protein, and 25% fat.

Calories

An athlete's calorie intake is proportional to the workout demands. The more an athlete trains, the more calories must be consumed to maintain weight. If a person is sedentary and consumes a high amount of calories, they will gain weight in the form of body fat. If an athlete does not ingest sufficient amounts of calories during demanding exercise routines, they will lose too much weight, become fatigued and level of performance will go down.

Caloric breakdown for nutrients:

1 gram of carbohydrates = 4 calories

1 gram of protein = 4 calories

1 gram of fat = 9 calories

Carbohydrates (CHO) 60%

Carbohydrates are the primary fuel source for athletes. During exercise, athletes draw energy from carbohydrates stored in the muscle and liver. During workouts greater than 90 minutes, an average athlete will deplete almost all of their stored glycogen. Complex carbohydrates (grains, cereals, breads, fruits, vegetables, and pasta) should be consumed more often. Simple carbohydrates (fruit juices, candy, and pop) should be consumed much less frequently.

****Athletes should consume 500-600 grams (2000-2400 calories) of carbohydrates per day****

It is more important to consume 100 grams of complex carbohydrates within 30 minutes of a workout to better replenish burnt stores of carbohydrates. It is also recommended to combine protein to your post exercise carbohydrate meal. Examples of this are:

Bagel or toast with peanut butter, 1 cup of fruit, and fresh fruit

1 cup fruit yogurt, gram crackers, and fresh fruit

Turkey sandwich and fresh fruit

Sport meal replacement drink

Protein 15%

Protein is used to build and repair tissue in the body. Quality, lean protein consumption can enable you to build quality muscle. Excess protein consumption is converted and stored as fat since our body can utilize a certain amount. Excess consumption can increase body water loss leading to dehydration. Protein is found in meats, fish, poultry, and dairy products.

Athletes should consume 0.8-2.0 grams/kg of body weight

Fats 25%

Fat is an essential part of our diet. It provides fatty acids necessary for normal growth and development; provides insulation; is used as energy in aerobic exercise/sports, spares protein loss, and is a vehicle for a fat soluble vitamins. Unfortunately, we tend to consume too much which can be detrimental to your health, appearance, and athletic performance. Common items with high quantities of fat are: red meats, pork, cheese, creams, sauces, mayonnaise, butter, salad dressing, and foods that are cooked oils (fried). When choosing items with fat content, look for the leaner cuts of meat.

Weight Gain and Weight Loss

The best way to gain weight is to consume more calories. Add nutritious snacks throughout the day. A realistic goal is to gain one pound per week (an additional 500 calories). Many athletes who are trying to gain weight do not even eat 3 meals a day. Start with a good breakfast. Add fresh fruit to your cereal in the morning and peanut butter on your toast. Remember that weight gain should not come in the form of added body fat.

Attempting to lose weight should not change the percentages of nutrients consumed. Rather, the quantity should be decreased. A realistic goal of weight reduction for an athlete is 1-1.5 pounds per week (decrease 500-750 calories). Do not skip meals. Eating at least 3 well balanced meals of smaller portions will achieve better results. Simple ways of decreasing calories are drinking skim milk instead of 2%, cut out the mayonnaise, butter and margarine.

Supplements

We do not recommend consuming supplements advertised for weight gain/muscle building such as creatine, amino acids, protein powder, etc. If you follow the guidelines in this manual, you will get all the nutrients including vitamins and minerals to be nutritionally successful. The only supplement we would recommend would be a meal replacement drink or bar immediately following a workout or if you are unable to eat a meal.

Conclusion

Good nutrition and hydration is imperative to good health and athletic performance. We realize it is impossible not to indulge yourself at times, but do so in moderation. A three meal a day diet for one week=21 meals. You should try to eat healthy for at 18 of those meals.

The following charts contain information on low fat, nutritious fast food choices; high carbohydrate foods; a guideline shopping list to help you select the proper foods; and a chart to determine how many calories you need to consume to maintain, increase, or decrease your weight based on current body weight.

MAKING LOWER FAT, NUTRITIOUS FAST FOOD CHOICES

<u>LOWER FAT CHOICES</u>	<u>MODERATE FAT CHOICES</u>	<u>HIGH FAT CHOICES</u>
<p><u>Dairy Foods</u> Low Fat Milk Frozen Yogurt Low Fat Milk Shakes</p>	<p>2%Milk Soft Serve Ice Cream Milk Shakes</p>	<p>Whole Milk Hard Ice Cream</p>
<p><u>Starches</u> Bagels, English Muffins Pancakes, Waffles Cereals Bread Sticks Baked Potatoes</p>	<p>Small Order French Fries Cornbread</p>	<p>Biscuit, Croissant Hash Browns Large Order French Fries Pastry, Pie or Brownie</p>
<p><u>Salad Bar</u> Salad Carrot, Celery Sticks Pasta Fresh Fruit Soups, not Cream Based Low Fat Dressing</p>	<p>Chicken, Tuna Salad Cole Slaw Macaroni/Potato Salad</p>	<p>Olives, Croutons Bacon Bits More than 2 tbsp of Dressing</p>
<p><u>Meats/Main Dishes</u> Chicken Filet Chicken Fajitas Grilled Chicken Sandwich Chili with Beans Plain Hamburger Vegetable Pizza Meat Sub or Sandwich Bean Burrito</p>	<p>Cheeseburgers Steak Sandwiches</p>	<p>Fried Chicken Fried Chicken Sandwiches Fried Fish Fried Fish Sandwiches Fish or Chicken Nuggets "Extra Size" Sandwiches Sausage/Pepperoni Pizza Bacon Burger Breakfast Biscuits Sausage or Bacon</p>
<p><u>Sauces</u> Catsup Mustard Barbecue Sauce</p>		<p>Mayonnaise Mayo-type Sauces Alfredo Sauce Hollandaise Sauce Added Butter or Margarine</p>

HIGH CARBOHYDRATE FOODS

FOOD GROUP	CALORIES	CARBS	FOOD GROUP	CALORIES	CARBS
MILK			FRUIT and VEGETABLES		
Low-Fat (2%)Milk (1 cup)	121	12	FRUITS		
Skim Milk (1 cup)	86	12	apple (1 medium)	81	21
Chocolate Milk (1 cup)	208	26	Apple Juice (1 cup)	111	28
Pudding, any Flavor (1/2 cup)	161	30	Apple Sauce (1 cup)	232	60
Frozen Yogurt, Low Fat (1 cup)	220	34	Banana (1)	105	27
Fruit Flavored Low Fat Yogurt (1 cup)	225	42	Cantaloupe (1 cup)	57	14
			Dates (10 dried)	228	61
			Fruit Roll-ups (1 roll)	50	12
BEANS			Grapes (1 cup)	114	28
Black Eye Peas (1/2 cup)	134	22	Grape Juice (1 cup)	96	23
Pinto Beans (1 cup)	235	44	Orange (1)	65	16
Navy Beans (1 cup)	259	48	Orange Juice (1)	112	26
Refried Beans (1/2 cup)	142	26	Pear (1)	98	25
Garbanzo Beans (Chick Peas) (1 cup)	269	45	Pineapple (1 cup)	77	19
White Beans (1 cup)	249	45	Prunes (10 dried)	201	53
			Raisins (2/3 cup)	302	79
GRAIN			Raspberries (1 cup)	61	14
Bagel (1)	165	31	Strawberries (1 cup)	45	11
Biscuit (1)	103	13	Watermelon (1 cup)	50	12
White Bread (1 slice)	61	12			
Whole -wheat Bread (1 slice)	55	11	VEGETABLES		
Bread Sticks (2 sticks)	77	15	Three Bean Salad	89	45
Cornbread (1 square)	178	28	Carrots (1 medium)	217	12
Ready to Eat Cereal (1 cup)	110	24	Green Peas (1/2 cup)	63	12
Oatmeal (1/2 cup)	66	12	Potato (1 Large)	220	50
Cream of Rice (1/4 cup)	95	21	Sweet Potato (1 Large)	118	28
Cream of Wheat (1/4 cup)	96	20			
Flavored Oatmeal (1 packet)	110	25			
Graham Crackers (2 Squares)	60	11			
Saltines (5 crackers)	60	10			
Triscuit Crackers (3 crackers)	60	10			
Pancake (4 inch in diameter)	61	9			
Waffles (2 - 3.5"x5.5")	130	17			
Rice (1 cup)	223	50			
Brown Rice (1 cup)	232	50			
Hamburger Bun (1)	119	21			
Hotdog Bun (1)	119	21			
Spaghetti Noodles (1 cup)	159	34			
Flour Tortilla (1)	85	15			
Oatmeal Raisin Cookie (1)	62	9			
Cheese Pizza (1 slice)	290	39			
Plain Popcorn (1 cup popped)	26	6			
English Muffin (1)	154	130			
Fig Bar (1)	50	10			
Low Fat Granola Bar (1)	109	16			
Pretzels (1 oz.)	106	21			

Step #1	Vitamin E	Vitamins A & C	Vitamin A	Vitamin C
Almonds	Broccoli	Brussels Sprouts	Apricots	Cauliflower
Corn Oil	Cantaloupe	Dark Green Salad	Carrots	Green Beans
Avocado	Dried Papaya	Grapefruit	Cheese	Kiwi
Guacamole	Red Peppers	Guavas	Green Peas	New Potatoes
Mayonnaise	Red Marinara	Mandarin Oranges	Peaches	Oranges
Olive Oil	Salsa	Mangos	Pumpkin	Pineapple
Peanut Butter	Tomato Juice	Sweet Potatoes	Skim Milk	Raisins
Peanuts	Tomato Sauce	Tangerines	Yogurt	Strawberries
Salmon	Tomatoes	Watermelon	Chili Powder	Pea Pods
Soybean Oil	V8 Drink	Yams	Catsup/BBQ Sauce	Radish
Sunflower Seeds	Winter Squash	Egg Yolk	Green/Yellow Pepper	
Sunflower Seed Oil				
Walnuts				

Step #2	Best Choice Carbs	2nd Choice Carbs	3rd Choice Carbs
Acorn Squash	All Bran Cereal	Apples	Baked Potatoes
Black Beans	Baked Beans	Banana Cake	Candy
Butter Beans	Bran Chex	Bananas	Cartoon Theme Cereal
Cherries	Brown Rice	Cornmeal	Doughnut
Pickles	Cheerios	Grapes	French Bread
Cucumbers	Cream of Wheat	Green Peas	French Fries
Egg Noodles	Lima Beans	Macaroni	Golden Grahams
Eggplant	Shredded Wheat	Oatmeal Cookies	Grape nuts
Fettuccini	Multi Grain Bread	Popcorn	Hash browns
Green Beans	Boiled New Potatoes	Pound Cake	Mashed Potatoes
Kidney Beans	Oat Bran	Raisins	Melba Toast
Lentils	Pita Bread	Ravioli	Puffed Rice
Mushrooms	Rye Bread	Spaghetti	Refried Beans
Nectarines	Special K Cereal	Sweet Corn	Sweetened Drinks
Onions	Tortillas	Sweet Potatoes	Total Cereal
Pears	Unsweetened Fruit Juice	Water Crackers	White Bread
Plums	Whole Grain Bread	Wheat Crackers	White Flour
Split Peas		Whole Wheat Flour	White Rice
Summer Squash			

Step #3	Best Choice Protein	Second Choice Protein	Third Choice Protein
95% Lean Ground Beef	2% Milk	Baked Chicken Strips	75% Lean Ground Beef
95% Lean Ground Turkey	85% Lean Ground Beef	Baked Chicken Nuggets	75% Lean Ground Turkey
95% Lean Ham	85% Lean Ground Turkey	Chicken-Dark Meat Skinless	Bacon
Beans and Peas	85% Lean Ham	Dark Meat Tuna in Water	Beef Ribs
Chicken-White Meat Skinless	85% Lean Encased Meats	Frozen Ice Milk	Pork Ribs
Fat Free Ice Milk	Low Fat Cheese	Low Fat Pudding	Chicken with Skin
Trimmed Beef Roast	Low Fat Yogurt	Nuts or Seeds	Fried Chicken
Trimmed Pork Roast	Regular Cottage Cheese	Peanut Butter	Fried Fish
Non Fried Fish	Regular Yogurt	Ricotta Cheese	Ham on Bone
Non Fried Seafood	Trimmed Lamb	Skim Mozzarella Cheese	Ice Cream
Skim Milk	Trimmed Beef Brisket	Trimmed Choice Steaks	Regular Cheese
Turkey-White Meat Skinless	Turkey Bacon	Trimmed Pork Chops	Regular Encased Meats
White Meat Tuna in Water	Turkey Sausage	Turkey-Dark Meat Skinless	Whole Eggs
Whole Grains	Whole Milk		
Sugar Free Yogurt			

Estimated Daily Caloric Intake to Current Body Weight

Weight (lbs)	Reduce	Maintain	Increase
100	1,535	2,035	2,535
110	1,740	2,240	2,740
120	1,940	2,440	2,940
130	2,145	2,645	3,145
140	2,350	2,850	3,350
150	2,555	3,055	3,555
160	2,755	3,255	3,755
170	2,960	3,460	3,960
180	3,165	3,665	4,160
190	3,365	3,865	4,365
200	3,570	4,070	4,570
210	3,775	4,275	4,775
220	3,975	4,475	4,975
230	4,180	4,680	5,180
240	4,385	4,885	5,385
250	4,590	5,090	5,590
260	4,790	5,290	5,790
270	4,995	5,495	5,995
280	5,200	5,700	6,200
290	5,400	5,900	6,400
300	5,605	6,105	6,605
310	5,810	6,310	6,810
320	6,010	6,510	7,010

Estimated Daily Intake in Relation to Caloric Intake

Caloric Intake	Carb (60% Intake (gm's)	Fat (25%) Intake (gm's)	Protein (15%) Intake (gm's)
2000	300	75	55
2500	375	95	70
3000	450	115	85
3500	525	130	95
4000	600	150	110
4500	675	170	125
5000	750	190	140
5500	825	205	155
6000	900	225	165
6500	975	245	180
7000	1050	265	195